

All 7/8" holes: every 2" on centerline.  
 Start & End 8" from either end. (19 holes)  
 Drill, then split car fully.

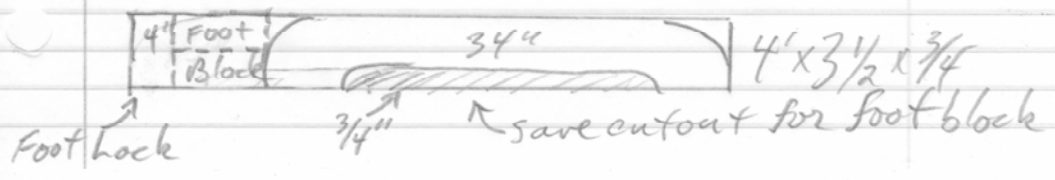
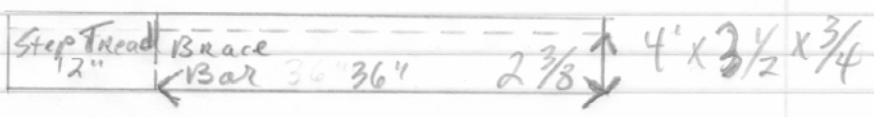
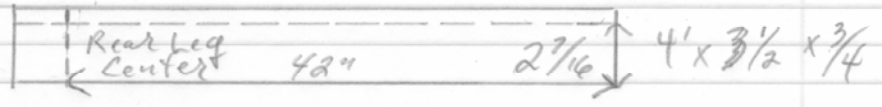
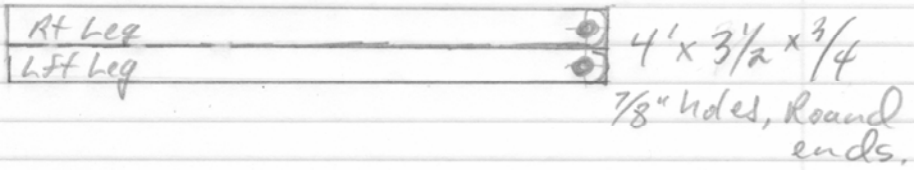

## **Materials:**

- (2) 5.5" x 0.75" x 5' Red Oak
- (5) 3.5" x 0.75" x 4' Red Oak
- (4) ½" x 6" galvanized threaded pipe nipple
- (1) ½" x 18" galvanized threaded pipe nipple
- (10) ½" Galvanized pipe caps
- (1) 2-½" T-hinge
- (2) 2-½" ¼ x 20 bolt with nut
- (2) Bottle caps from 2-L soda bottle or similar
- (1) Tube of 2-part epoxy
- (1) Ratcheting web strap – at least 48" long.

## **Instructions:**

1. Begin by cutting 5.5" x 5' board to 50" for the front panel of the chair. Save remaining piece (appx. 10") for the **Seat Box**.
2. Rip second 5.5" x 5' board down the center into 2 pieces, (appx. 2.75" wide)
  - a. From the first piece, cut four 14" pieces – these must be glued up to form the **seating surface**. Save the last piece (appx. 4") for the **Receiver**.
  - b. From the second piece, cut two 14" pieces (for R & L side of **seat box**), two 10" pieces (for R & L side of **step box**), and two 5-5/8 wide pieces (for the front piece of both seat and step boxes).

NB: These last pieces **MUST** be a bit wider than 5.5" in order for the seat and step to adjust easily!
3. Clamp together two 14" pieces of the seat box and drill a 7/8" hole centered 7/8" from the upper, rear corner as shown below.
4. Assemble the **Seat Box** (part 1) by gluing up as shown below. I use 1-½ corrosion-proof deck screws on each side for strength. Make sure the holes are aligned when gluing! The rear panel of the seat box must be added later! Proper position of the rear panel is very sensitive to the angle of the A-frame – this must be determined after the A-frame is assembled!
5. Assemble the **Step Box** (part 1) by gluing up as shown below. I use 1-½ corrosion-proof deck screws on each side for strength. All screws are counter sunk, and filled with wood filler.

**Seat Box / Step Box  
Assembly  
Part 1**

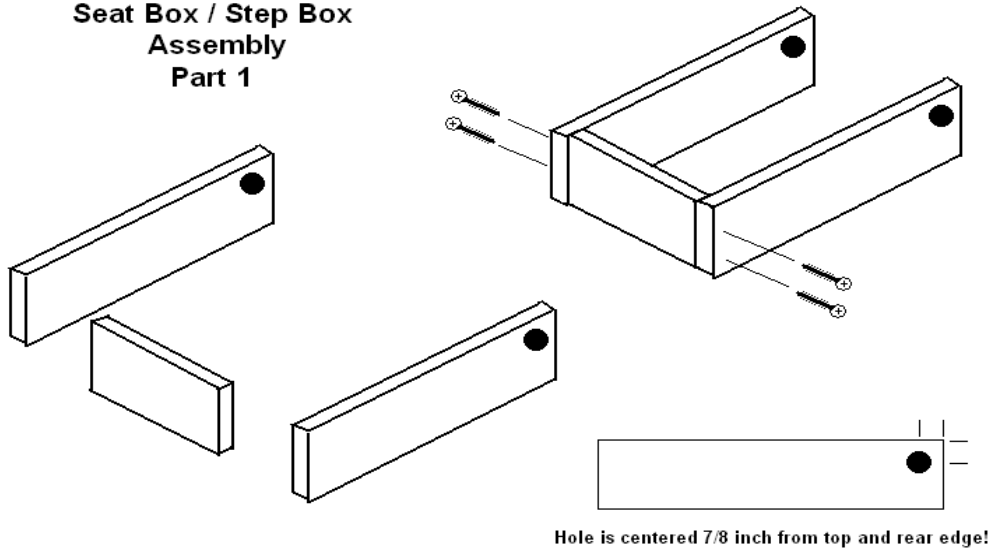

6. Start with a 3.5" x 0.75" x 4' board, and mark a centerline.
  - a. Mark hole centers starting 8" from one end, and mark every 2". You should end up with 19 holes, each 7/8".
  - b. Split the board down the midline to make the right and left rack for the chair. Sand and true the flat edge opposite the rack.
  - c. Drill a 5/16" hole edgewise through each rack as shown. Bore out the hole to 1/2" wide for the first 1/4" of depth. This will be the attachment point for the foot board at the bottom of the rack.

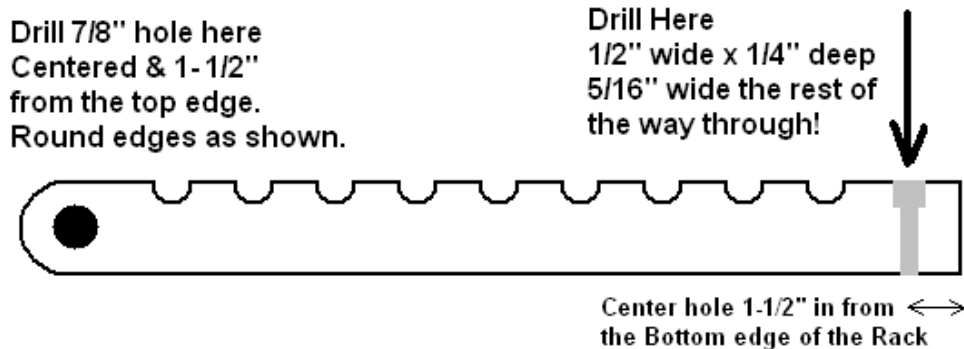

7. Start with a 3.5" x 0.75" x 4' board, and mark a centerline. Split the board down the mid-line to make the right and left rear legs.
8. Take the four pieces from step 6 & 7, and mark a mid-line on one end only. Measure 1-1/2" from the end and mark the center for a 7/8" hole. (You may wish to clamp all 4 together and drill them all at once to insure better alignment – but only if you have a drill press. Otherwise,

drill each separately by hand.) After drilling, round the ends. Again, clamping and gang-sanding works well here.

9. Start with a 3.5" x 0.75" x 4' board, and trim to 42"; then rip down to 2 - 7/16" to make the rear leg center piece.
10. Start with a 3.5" x 0.75" x 4' board, and trim to 36" – save the remaining piece for the step box tread. Rip the 36" piece down to 2 - 3/8" to make the brace bar.
11. Start with a 3.5" x 0.75" x 4' board, trim to 34", save remaining piece for the foot block and foot lock components.
  - a. Measure in 5" from each end of the foot board and cut a 3/4" recess with a jigsaw or band saw. Save the cutout – it will become part of the foot assembly!
  - b. Now take the cutout and remove a 5" piece from each end.
  - c. Cut a 5" piece from the appx. 12" piece just removed in step #11. Split this piece into two identical pieces; appx. 5" x 1-3/4". Glue them onto the 5" cutout pieces as shown here:

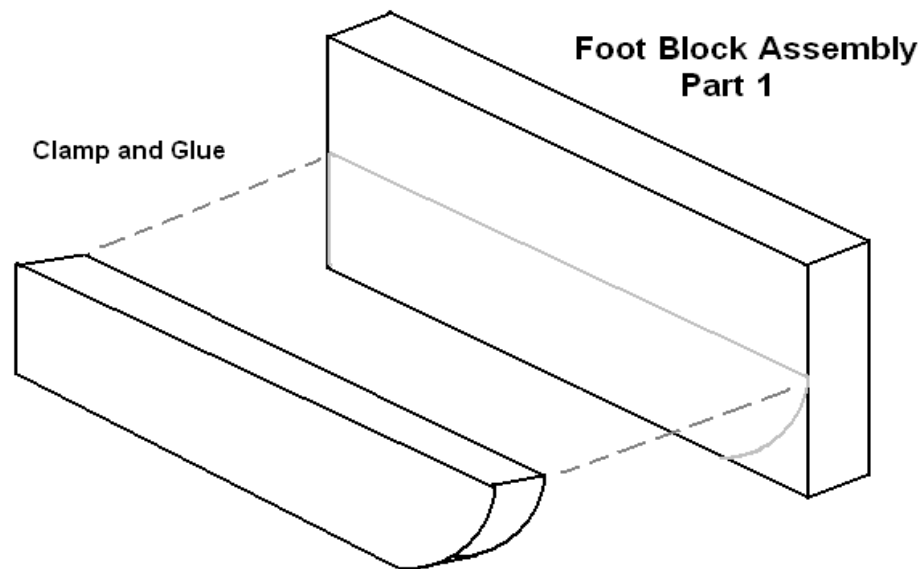

- d. Once it is glued, round off the corner of both foot blocks on a belt sander and set it aside – it will be finished and attached to the foot board later.
12. Take the 50" front panel piece and cut a handle into it by drilling two 1" holes centered 1-3/4" from the top edge, and 1-3/4" from the sides, then connect the two holes with a jig saw & sand smooth. Round the corners with above the handle with a jig saw or belt sander.

13. The rack pieces must now be be attached to the back of the front panel. I use tightbond III glue and screws (for shear strength) as shown below, but biscuit joinery, dominoes, or dowels can be used. Be sure the bottom of the rack protrudes 2-3/4" below the bottom edge of the main panel – this will be the point where the foot is attached later. See below:

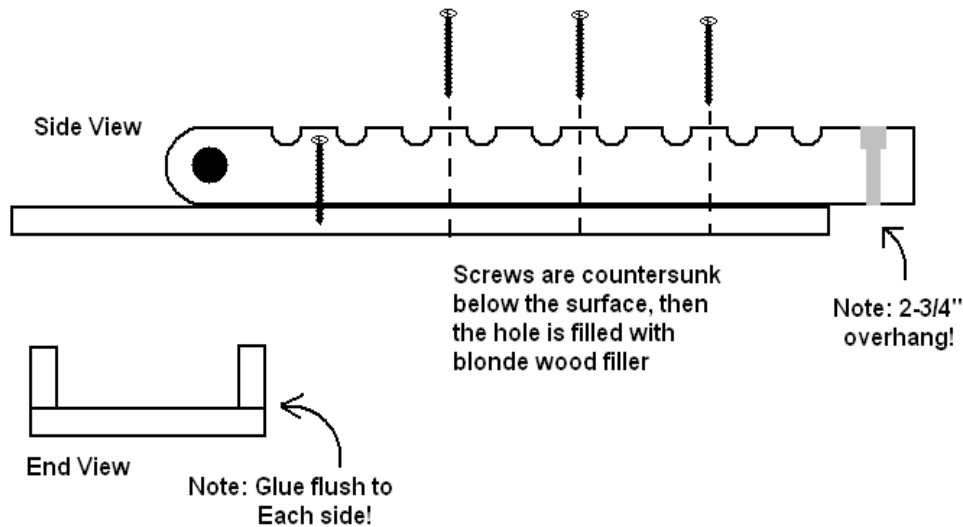

14. The next step is assembling the rear leg. Take the two identical pieces from step #7 (48" x 1.75" each), and the single piece from step #9 (42" x 2-7/16"). Clamp and glue as shown below. I do not use screws on this sub-assembly, because there is no shear force on this part, (all the weight is carried in compression.)

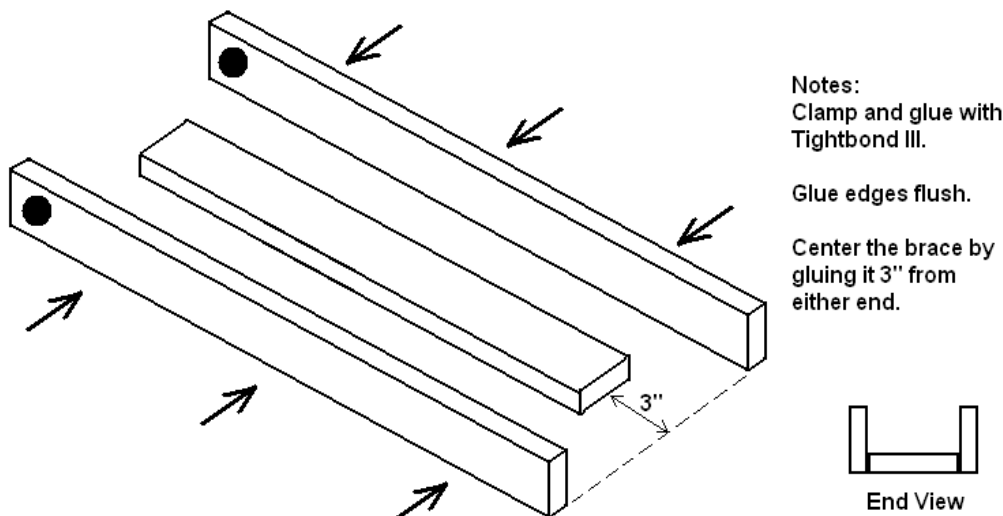

15. Next, the foot board must be drilled out to allow it to be attached to the main panel. Lay the main panel face down (racks are now UP!) Place the foot board flush against the bottom of the main panel, and make sure that it is centered. See below:

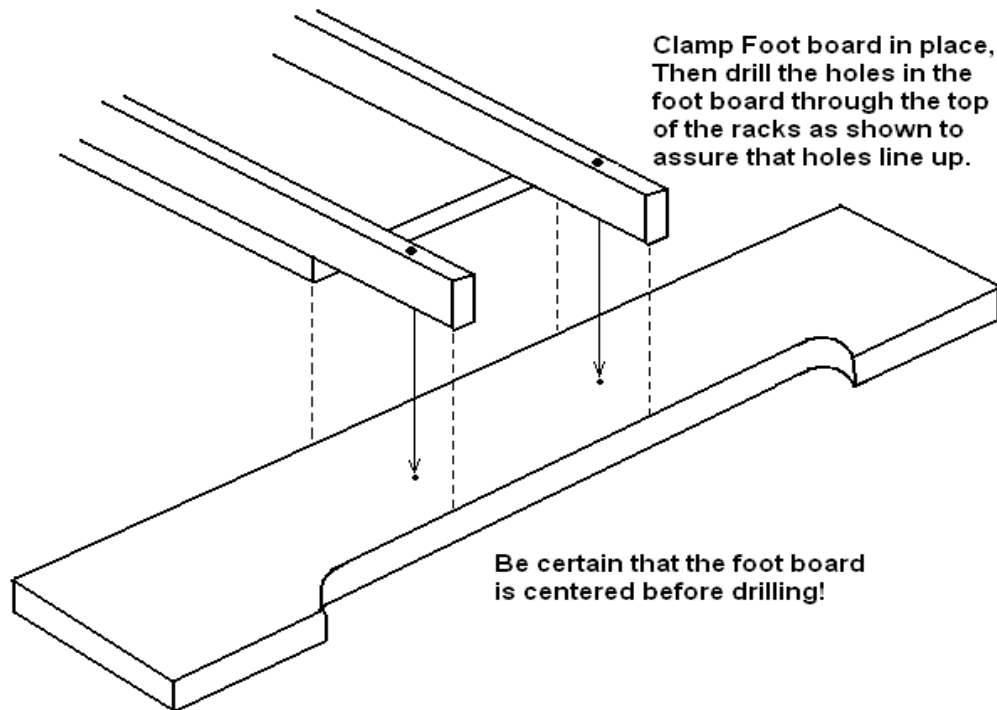

16. With the foot board clamped in place, it is time to install the locking tab on the foot board. Take the piece you set aside from step #11 for the foot lock tab, and trim it to 3" x 4". The 4" side should be exactly wide enough to fit precisely between the racks on the back of the main panel you assembled in step #13.
- Place the locking tab so that it overhangs the top of the foot board by exactly 1- $\frac{1}{4}$ " and glue it in place.
  - Glue the locking tab to the foot board only – DO NOT glue it to the main chair panel!!!***
  - Secure the tab in place with two, countersunk 1" screws.
  - With the foot board still clamped in place, drill 5/16" holes in the foot board by drilling ***through*** the rack pieces. This will assure the holes in the rack and foot board line up perfectly and assemble easily in the field.
  - Important!!!*** Once the locking tab is screwed into place and the holes have been drilled through the foot board, remove the foot board from the main panel assembly, wipe any excess glue away and allow to dry.

17. For the next step, mount the T-hinge on the back side of the main panel (the one with the racks now attached). Center the hinge, and mount it 2" from the bottom edge of the main panel (as shown below), with the crosspiece fastened down and the tongue of the hinge free.

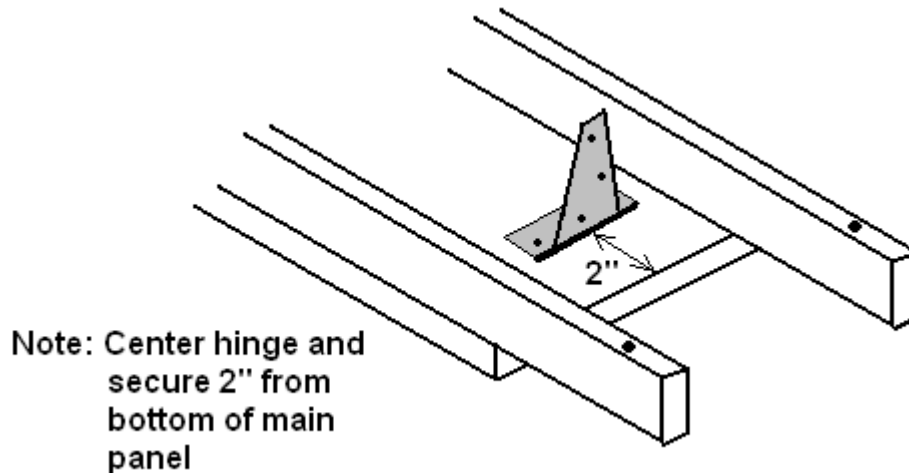

18. Create two tool-less knobs using caps from a 2-Liter soda bottle and 1/4-20 x 2-1/2" bolts. (Stainless steel is a good idea, as these may be exposed to moisture during use.) Drill a 1/4" hole in the soda cap as shown below, force the bolt through, and secure a washer and nut on the other side. Now fill the cap with common epoxy and allow to cure thoroughly. I usually paint the finished knobs with gloss black enamel and put a piece of stick-on felt on the bottom side of the cap.

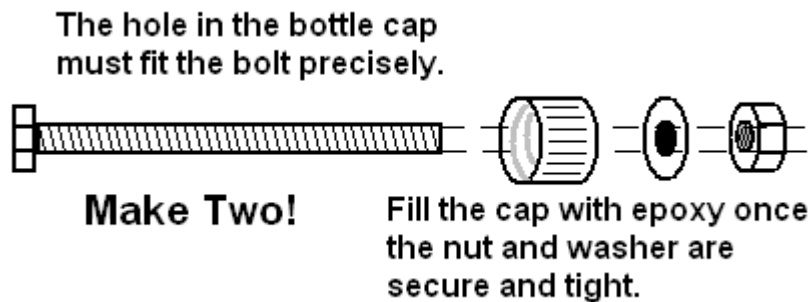

19. Now the T-hinge tongue can be preliminarily secured to the top of the brace bar. Be sure that the brace bar is *centered* when attached! Once the brace bar is secure, fold it flat against the main panel. I used a Dremmel tool as a router to make a recess for the hinge, and the screw heads, but this is optional.
20. With the brace bar folded flat, lay the rear leg over the brace bar (it should fit neatly into the space between the two racks on the main panel.) Use one of the 6" galvanized pipes and caps to pin the leg and the main panel together at the top; this pipe will act as the main hinge between the front panel and the rear leg.

21. Once the knobs are completely cured and the glue from step #16 is completely dry, the foot board can now be attached to the main panel.
- Begin by pressing the two, ¼-20 nuts into the large holes on the lower end of the racks (they should fit snugly – if not, hold them in temporarily with a piece of masking tape.)
  - Lay the main assembly on the floor with the main panel face up, slip the foot board into place – the locking tab should center it perfectly – and attach it with the two tool-less knobs. If everything is working correctly, the nuts can be secured in place with a bit of epoxy or a couple of drops of superglue. Make sure you don't foul up the threads!
  - Note: if the bolt is too short to reach the nut, you may have to deepen the ½" wide hole on the back of the rack.
22. Now that the foot board is attached correctly – you can set up the A-frame of the chair for the first time. It is highly recommended that this be done on a *carpeted surface*, because the frame is not secure at the bottom yet and it can slip and collapse!
- Keeping the unit closed, stand the main assembly upright.
  - Pull the leg out slowly, and lower the brace bar. The brace bar should fit between the two rear legs, and protrude just slightly.
  - Lift the foot board slightly, and place the two foot blocks from step #11 underneath the foot as shown below.
  - Looking at the A-frame of the chair from the side – use a level and strike off a line on the foot blocks and on the rear leg as shown below. By trimming off the foot blocks and rear leg on this line – the entire assembly will sit flat when fully open, making it much more stable and floor friendly, too! (I use a belt sander for this.)

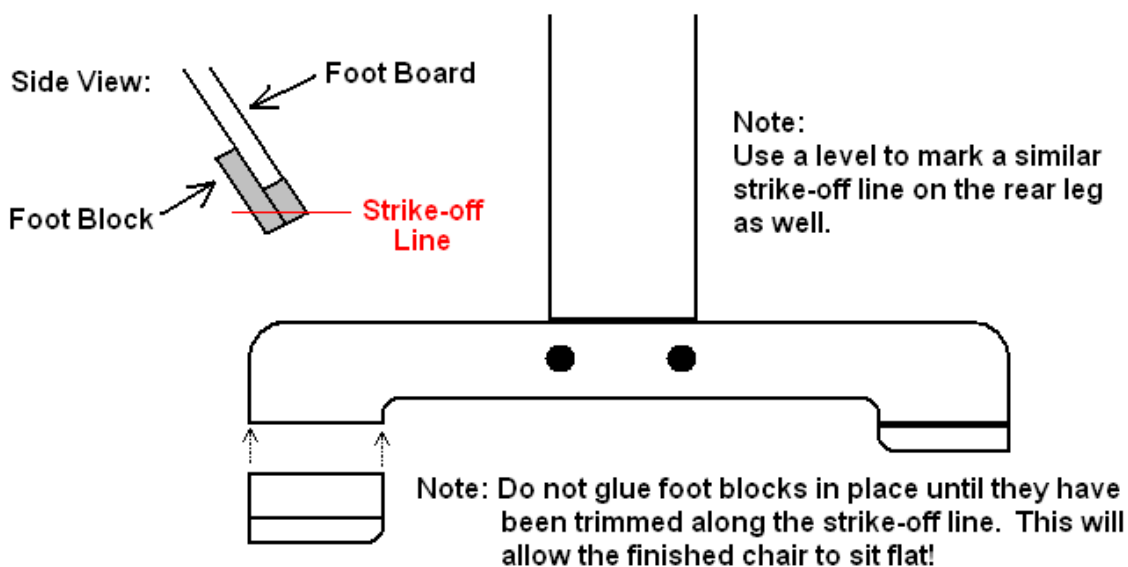

23. Once the foot blocks have been trimmed, they can be glued and clamped securely in place and allowed to dry. The foot board now has a wider, more secure platform to carry the weight of the chair and observer.
- a. Optional: I purchased an inexpensive rubber-backed, nylon door mat and cut two pieces to fit the bottom of the foot blocks. This was glued in place with liquid nails, and serves as a floor-friendly pad when the chair is assembled or used indoors.
24. Next, the receiver can be glued between the lower ends of the leg as shown below.

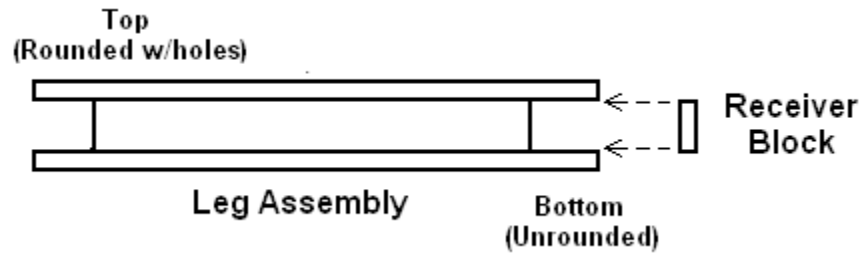

25. I attached a corner brace to the top of the brace bar as shown below. Before attachment, I used a router to insure that the top of the corner brace was flush with surface of the brace bar itself. This is essential to insure that the chair will close properly. The corner brace was trimmed so that it doesn't extend below the receiver. With the brace bar in place, drill a hole through the corner brace and into the receiver. This will allow a locking pin (made from a double headed nail) to secure the brace bar in place.

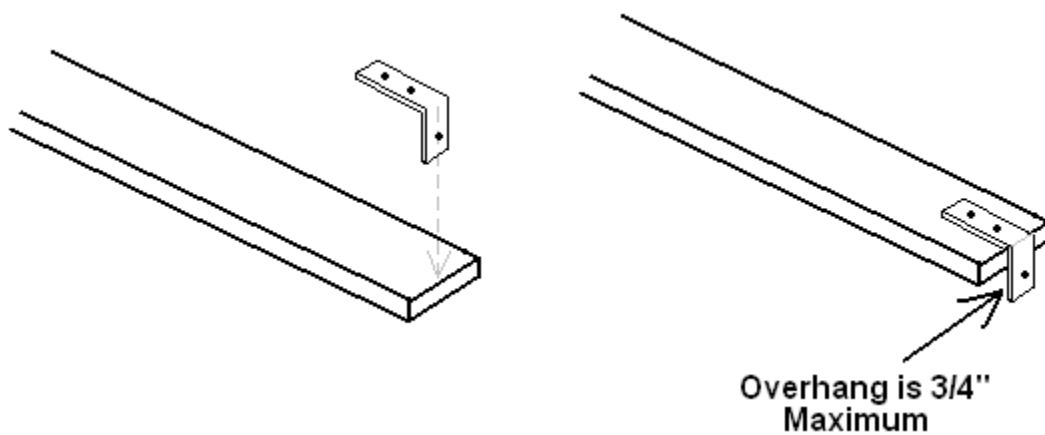

26. To make the locking pin, I cut off a double headed nail and then cut a thin strip ( $\frac{3}{4}$  x 2") from the nylon door mat (see step 23-a), drilled a hole in one end and epoxied the double headed nail in place. Screwing down one end of the matting strip to the receiver holds everything in place. See photo below:

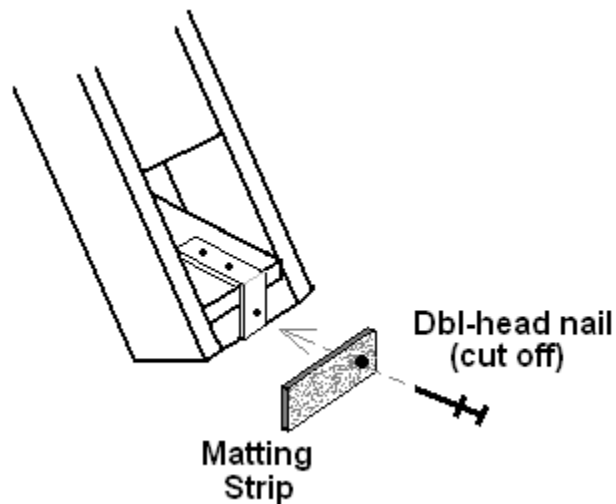

27. The main frame of the chair is now almost finished. Remove the locking pin and gently fold the seat closed. You will find that the corner brace now prevents the frame of the chair from folding completely. A tap with a rubber mallet will cause the corner brace to make a slight mark on the inside of the folded chair leg. Use a Dremmel to route out a recess in the correct place so that the corner brace fits into it when closed. Don't worry about appearance too much here – this is on the upper inside of the leg and will not be visible when the chair is open or closed.
28. Last of all, I glued a square of Velcro between the brace bar and the back of the main panel. I realized this was needed after getting my knuckles whacked by a free-falling brace when trying to open the chair! The Velcro insures that the brace remains in the folded position until you are ready for it. The main A-frame of the chair is now finished.
29. With the main frame of the chair now complete, the seat and step boxes can now be finished. In order to do this, the main frame must be assembled and placed on a level surface. Begin with the step box: slip the open end of the box over the front of the chair frame and insert the 6" pipe through the holes. You can now mate the pipe to any one of the notches on the rack and use a clamp to hold the box and frame together in this position. Use a level to make sure the step box is horizontal, and mark off the line to show the angle of the front of the chair frame on the inside of the box as shown below.

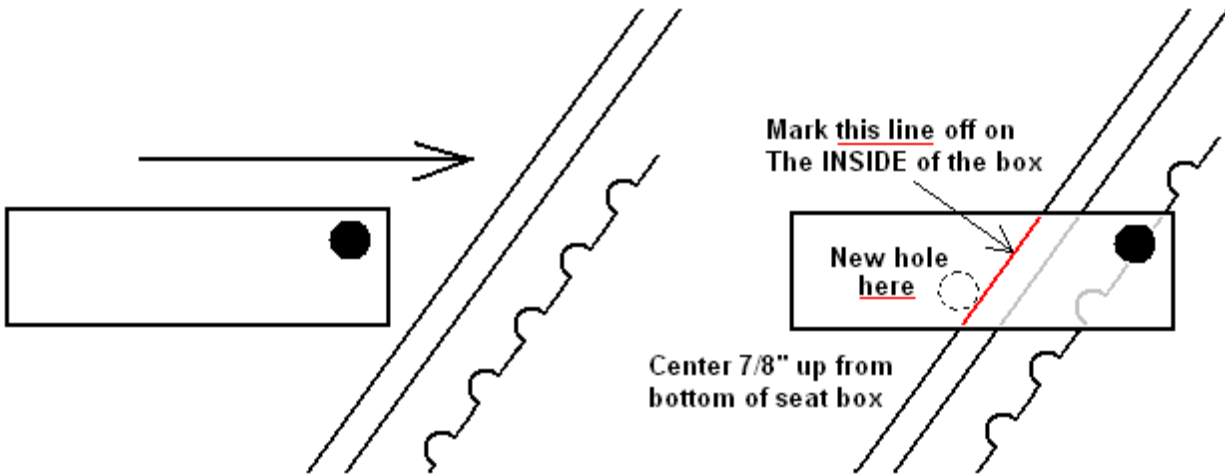

30. After marking the location of the new hole and drilling it out, you can now mount the seat box with both 6" pipes in place. The seat box should lock into place easily and remain level at every position.
31. The step can now be glued to the top of the seat box. The step should be flush with the front edge of the step box. In no case may the back edge of the step extend beyond the center of the front hole in the side of the seat box – if this occurs, you may not be able to lift the step and adjust it easily.
32. Steps 27-28 can now be repeated with the seat box.
33. To finish the seat box, take the piece cut from the main panel in step #1, and fit it into the seat box as shown below. The piece must be trimmed as shown so that it fits flush with the top and bottom of the seat box as shown. The brace forms the rear of the seat box and must not extend beyond the rear edge of the front hole in the seat box as shown. Drill the third hole in the seat box as shown – this will be used to store the last galvanized pipe when the chair is folded closed.

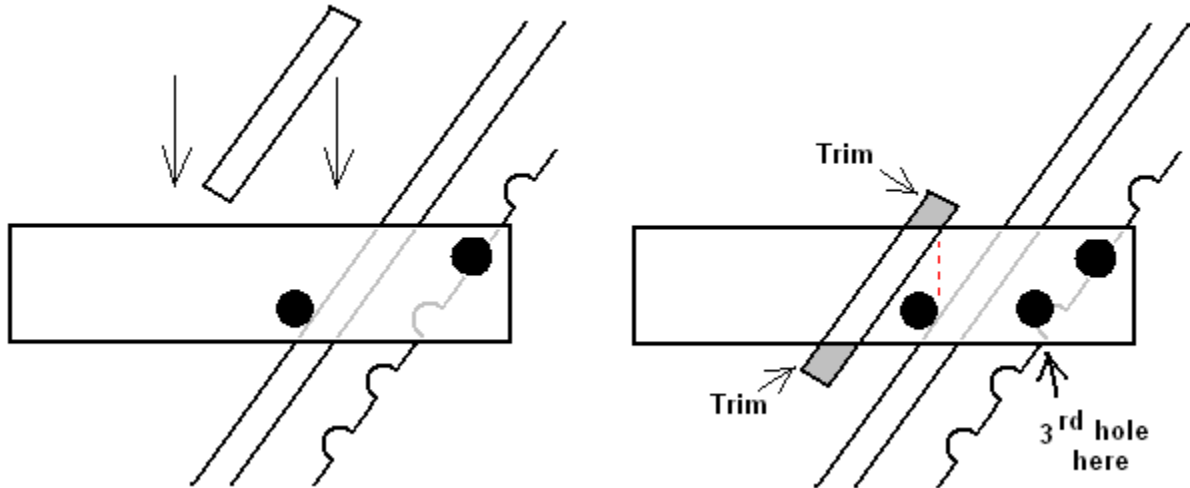

34. With the seat box complete, install a short piano hinge on the back of the brace. The seating surface itself, (glued up in step #2-a) can now be attached to the piano hinge to form the top of the seating box. (You may wish to round the corners to make the seating surface more comfortable.) In order to keep the box closed, I used Velcro – any equivalent fastener can be used.
35. The next step is to make a mounting point for the leg when the chair is folded up. To do this, remove the step and seat boxes, and fold the chair completely closed. Use the longer (18") galvanized pipe to connect the two boxes together as shown.

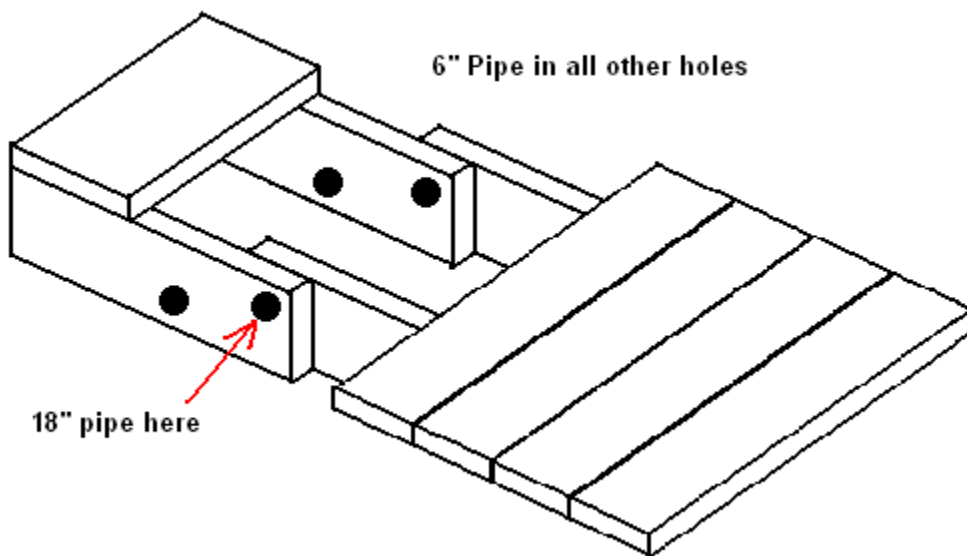

Insert the remaining 6" pipe into the 3<sup>rd</sup> hold drilled in the seat box in step #33. You can now hang the step box over the top of the close frame in its stored position, and lay the assembly flat on

the floor *face down*. Lay the finished foot board on the closed leg and, using it as a template, use a nail to mark the position of the holes onto the leg itself (similar to what was done in step #15). Be sure to have the seats linked and in place on the top of the folded frame when the holes are marked – this way, the leg cannot interfere with the seat box when the unit is closed.

36. 5/16” holes must be drilled through the leg and the brace bar in the marked position. Take very great care that you do not drill through the main front panel!!! Set your drill depth so that the bit drills through the leg and into the brace (without going through it.) You should disassemble the main frame and finish drilling the holes in the brace bar. The holes must be widened to ½” on the top of the brace bar so that nuts can be epoxied there (as in step #6-c.) If all is done properly, the foot board can now be fastened down to the back of the closed chair frame when it is folded up. This will secure the foot and keep the frame closed when it is transported!
37. The chair is now almost complete, and can be disassembled and stained/finished as you prefer. I used a polyurethane finish to make the chair weather resistant.
38. For the last step, you can attach the ratcheting web strap. The strap with the ratcheting mechanism should be attached to the *inside-right* of the seat box. I use epoxy and a staple gun for this. There must be enough webbing so that the ratcheting device can reach around to the opposite side of the folded chair assembly when the linked seat and step boxes are hung off the top of the folded frame as in step #35. The rest of the webbing can be cut off and attached to the inside-left of the seat box. With the webbing hanging out of the seat box, the ratcheting mechanism will cinch the seat and step boxes to the folded chair for transport. (See picture below). The webbing and ratcheting mechanism can be stored in the seat box when not in use so it will not be in the way.

The chair should now be complete, and ready to use. Enjoy!



Questions or comments? Please contact Daniel Barth at:

[voyagerdan@hotmail.com](mailto:voyagerdan@hotmail.com)